

B - B

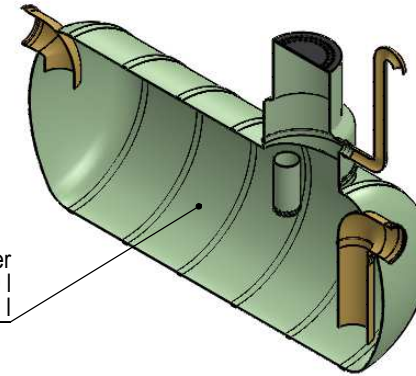

Oil separator chamber
oil layer volume 750 l
useful volume 5700 l



Separator max. flow: 50 l/s

h = inlet distance from ground (default 1500):

Item	Part	Description	Std. qty.	Need
1	Separator housing	fiberglass, ϕ 1600 x 3750	1	
2	Inlet-/outlet sewer	DN315	2	
3	Maintenance shaft	ϕ 800/600	1	
4	Oil removal shaft	ϕ 200	1	
5	Ventilation outlet	DN110	1	
6	Level alarm device		1	
7	Top cover	plastic	1	
		cast iron		

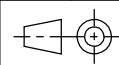

Weight

Date

7.04.2021

Drawn by E. Väljaots

Drawing no. KPP.50.01



Klaasplast OÜ
reg.kood: 11862070
tel: +372 5691 1914
info@mahuti.ee
www.mahuti.ee

Title

II-class oil separator

Sheet
1/1

Scale
1 : 40

Article no.

NS50